

Reliable Power

LP100C-series

LED Power Supply

100W AC/DC power supply for LED lighting

Universal AC input

Outputs: Dual 350mA or single 700mA

The LP100C series of high efficiency fully isolated AC/DC power supplies are designed for the high demands of LED Lighting applications. They provide dual outputs of 350mA or a single output of 700mA.

Each output uses current control and can drive a string of up to 40 HB-LEDs directly, eliminating the need for external drivers.

These power supplies are configured in an open frame metal chassis for excellent cooling within the housing. Fully enclosed IP67 packaging is available for use in damp locations.



Key Features

- Universal AC input range
- Constant current outputs, 350mA or 700mA
- High efficiency >90%
- Size 7.8" x 2.6" x 1.53" (200 x 65 x 39 mm)
- High reliability, long life
(>10 years continuous operation @45°C)

Standard Features:

- High power factor >0.95
- Internal overvoltage protection
- Internal input fuse
- -40°C to +80°C baseplate
- Thermal shutdown protection
- Full safety approval (UL, cUL, CE)
- Input and output terminal blocks
- RoHS compliant
- Conformal coating of PCB
- Optional IP67 housing
- 5-year factory warranty



PERFECT IN FORM AND FUNCTION

AEG

INPUT

Nominal voltage	100/120/208/240 Vrms
Voltage range	85-264 Vrms (47-63Hz)
Low input shutdown	<85 Vrms. Automatic restart
Power factor	>0.95 at full load
Efficiency	>88%@ 110Vrms, full load >90% @ 220Vrms, full load
Inrush current	<35A @ 220Vrms, cold start
Input fuse	4A internal input fuse
Reflected noise	Meets CISPR Class A stand alone
Leakage current	<2mA at 230Vrms
Thermal shutdown protection	>110°C internal temperature. Automatic restart
Connector	Screw terminals, 3 pole (flying leads with IP67 enclosure)
Switching frequency	Variable frequency

OUTPUT
DUAL OUTPUTS (EACH OUTPUT)
SINGLE OUTPUT

Output current, nominal	350mA	700mA
Overcurrent fault protection	1A maximum	2A maximum
Output ripple and noise	<50mA pk-pk	<105mA pk-pk
Output power	91W maximum	
Output current regulation	+/-6%	
Output voltage, minimum	0V (short-circuit)	
Output voltage, maximum	130Vdc	

NOTE: Because the current is regulated rather than the voltage, the PSU will go into hiccup mode if the output terminals are open circuit.

Overvoltage protection	<200Vdc
Connector	Screw terminals, 2 pole (flying leads with IP66 enclosure)

ENVIRONMENT

Environmental protection	Conformal coating standard. IP67 enclosure optional
Cooling	Conduction cooling through housing
Operating temperature range	-40°C to +80°C baseplate
Storage temperature range	-40°C to +85°C
Humidity	0% to 95% non-condensing
EMC	FCC / CISPR 22 class A
Vibration	10 – 55Hz, 2g 1min/cycle period of 60min, x, y, & z axes

SAFETY/MARKING

Input / output isolation	3000 Vrms
Input / case isolation	1500 Vrms
Output / case isolation	500 Vrms
UL, cUL, CE	UL60950-1, UL8750

MECHANICAL

Dimensions	Open frame version: 7.8" x 2.6" x 1.53" (200 x 65 x 39mm) Enclosed version: 8.9" x 3" x 1.77" (226 x 76 x 45mm)
Housing	Metal baseplate and enclosure
RoHS	RoHS 6

RELIABILITY

Design life	>10 years continuous operation @45°C, full load
MIL-HDBK-217F, 45°C, 100% load	>300,000 hours MTBF @ 45°C

 Outline drawing (LP100CD35B00 and LP100CS70B00)

All dimensions in mm

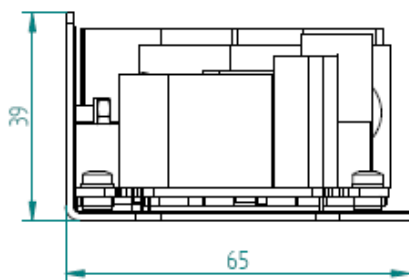
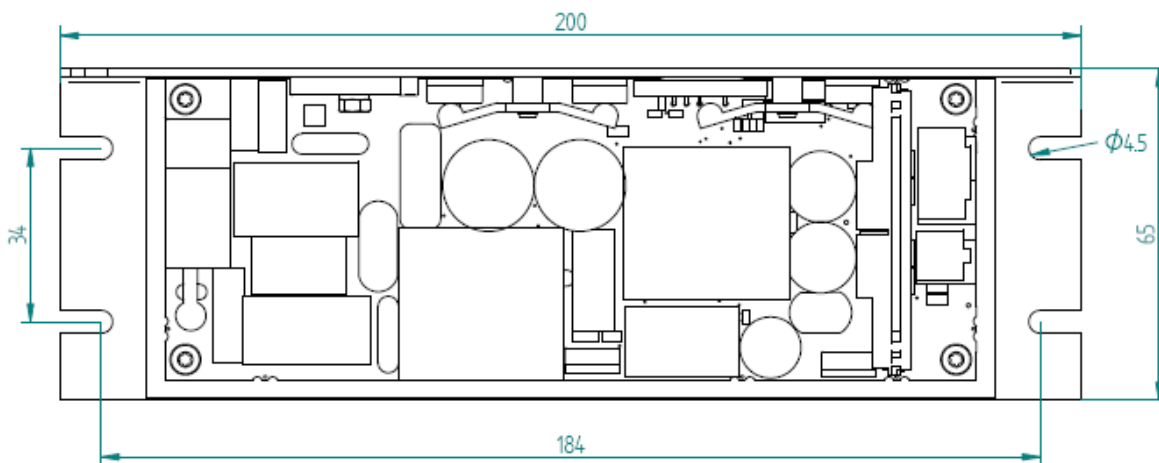
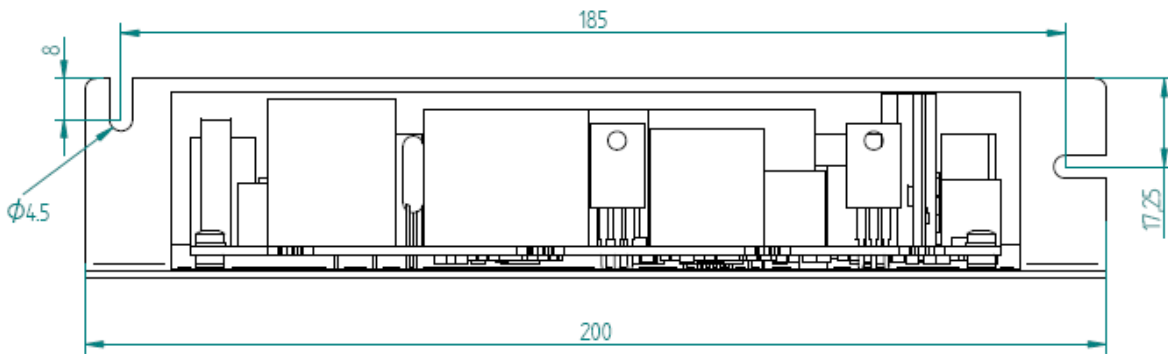
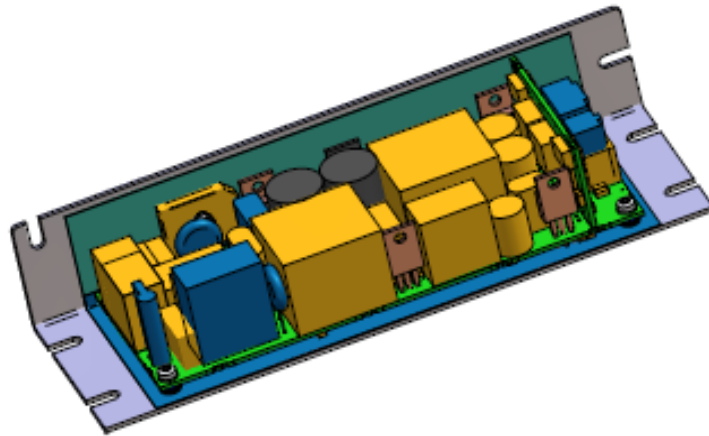

 Outline drawing (LP100CD35B67 and LP100CS70B67)

All dimensions in mm

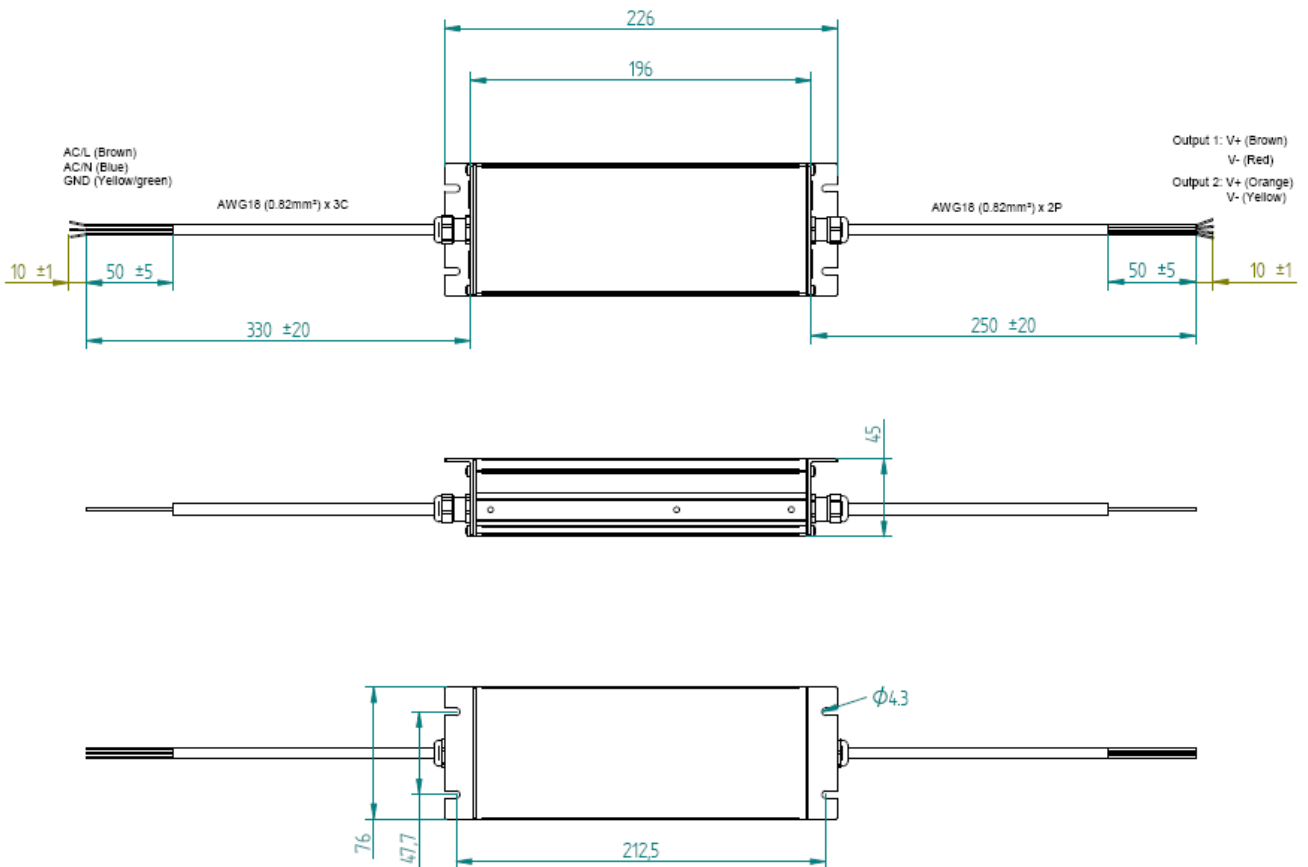
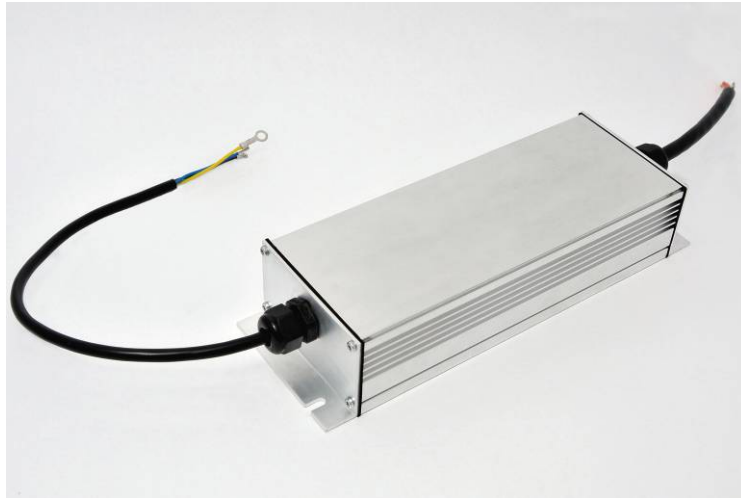

PRODUCT VERSION	PART NUMBER
Dual 350mA outputs, conformal coated	LP100CD35B00
Dual 350mA outputs, IP67 enclosure	LP100CD35B67
Single 700mA output, conformal coated	LP100CS70B00
Single 700mA output, IP67 enclosure	LP100CS70B67

Part Number System with options

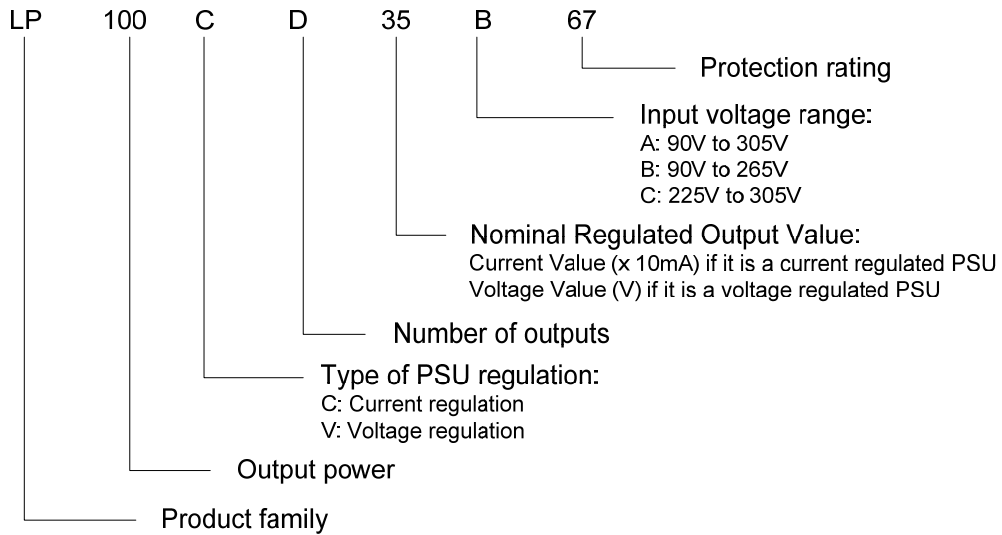

Output load

The LP100C series uses current control to regulate the output current rather than the output voltage. This allows it to drive a string of LEDs directly without the need for a separate driver. With this mode of regulation, the PSU output voltage automatically adjusts to accommodate the load.

It is important to remember that this type of PSU cannot operate without a load. **If the output terminals are left open circuit, the voltage will rise to the overvoltage protection threshold and the PSU will go into "hiccup mode".**

Mounting

The LP100C series is designed to be mounted to a metal surface that can act as a heatsink, such as the housing of a luminaire. It is recommended to carry out testing in the final configuration to confirm that the baseplate temperature is not excessive under worst-case operating conditions. If the baseplate exceeds +80°C the thermal protection may cause the unit to shut down. Harmer and Simmons can provide assistance with thermal design and simulation if required.

Reliability

The LP100C series is designed to provide very high reliability and long life under all normal operating conditions. All components used in the design are operated well within their ratings, following Harmer and Simmons' derating policy. No further derating of the power supply is necessary, and the unit can be used at any load up to its maximum rating.

The MTBF prediction given on page 2 of this datasheet assumes typical long-term operation at 100% load, with a baseplate temperature of +45°C. Short-term excursions above this temperature will not significantly affect the MTBF, provided the maximum rated baseplate temperature is not exceeded. If the power supply is used in an environment where the sustained operating temperature is significantly higher than +45°C, the MTBF will be reduced accordingly.

In many lighting applications the lights are only on for a portion of the day, and the power supply lifetime will be extended in proportion.

Voltage transients

The LP100C series includes internal protection against voltage transients due to lightning and other AC power line surges. In some applications such as highway lighting where there may be an unusually high level of power line surges, it may be necessary to use additional surge protection external to the power supply. This protection can be achieved using surge suppressors such as Transzorbors or MOVs connected across the AC input terminals of the power supply.

Outdoor environment

The LP100C series is normally manufactured with conformal coating of the PCB assembly to provide protection against dust and contaminants. This version is suitable for most applications, including outdoor lighting where the product housing can provide sufficient protection for both the light engine and the PSU.

The LP100C is also available with an IP67 enclosure for use in damp locations. This version is suitable for applications where the PSU is not well protected and may be subject to water splashing directly onto the PSU enclosure.

Safety

The LP100C series meets North American and international safety specifications at the component level, and is certified according to UL, cUL and CE. It is designed to be mounted inside a final product enclosure and it is the user's responsibility to obtain safety approval for the final product.

The power supply includes an internal input fuse. Additional external protection may be needed in some cases, depending on the details of the application.

Dimming

The LP100C series does not support dimming. If your application requires dimming, Harmer and Simmons has other products available that can be dimmed through industry-standard dimming interfaces.

AEG is a brand licensed by Electroflux AB